



<http://gonaweld.com>

## CR SERIES/ CONVENTIONAL WELDING ROLLERS

### CR INTRODUCTION

CR CE Series rollers feature an all-fabricated-steel base construction with wheel carriages that can be positioned by manual bolts, allowing for adjustment of the centerline to accommodate vessels of varying diameters. Each unit includes one drive unit and one idler unit

The drive motors are inverter controlled variable frequency AC type with fan cooling. Drive two reduction worm and wheel gearboxes are used for enhanced durability and extended overhaul intervals.

Drive and idler wheel shafts are housed in deep groove type roller bearings and synchronous rotation.

Control boxes have utilized variable frequency AC control electrical systems with full CE certification to ensure all our products establish safe working loads in the weld automation industry.



Standard Bolt Adjustment Roller



With Traveling Wheels on Rails

## 5 TO 80 TON LOAD CAPACITY

### CR SPECIFICATIONS //// ROLLER SET CAPACITY

Model	CR-5	CR-10	CR-20	CR-30	CR-40	CR-50	CR-60	CR-80
Turning Capacity	5 tons	10 tons	20 tons	30 tons	40 tons	50 tons	60 tons	80 tons
Loading Capacity-Drive	2.5 tons	5 tons	10 tons	15 tons	20 tons	25 tons	30 tons	40 tons
Loading Capacity-Idler	2.5 tons	5 tons	10 tons	15 tons	20 tons	25 tons	30 tons	40 tons
Vessel size	350-5000 mm	350-5000mm	350-5000mm	570-6800mm	570-6800mm	570-6800mm	570-6800mm	570-6800mm
Adjust Way	Bolt adjustment							
Motor Power	2*0.37 KW	2*0.55 KW	2*0.75KW	2*1.1 KW	2*1.1 KW	2*1.5 KW	2*2.2 KW	2*3 KW
Rotation Speed	100-1000mm/min Variable Frequency Driver							
Roller wheels	Rubber / PU / Steel Wheels all available							
Roller size	Φ250*140mm	Φ300*180mm	Φ350*180mm	Φ350*220mm	Φ400*220mm	Φ400*220mm	Φ450*300mm	Φ500*360mm
Voltage	220V / 380V / 415V / 440V / 480V / 575V ~ 50/60Hz 3Phase							
Control system	Remote hand box 8m cable (Rotation Forward & Reverse / Stop / Emergency Stop / Rotation speed display)							
Color	RAL 3003 RED+9005 Black							



**CR SERIES/ CONVENTIONAL WELDING ROLLERS**



100Ton Motorized Traveling Growing Line



200Ton Onshore Line



Wireless Hand Box



Remote Hand Box

**100 TO 1000 TON LOAD CAPACITY**

**CR SPECIFICATIONS //// ROLLER SET CAPACITY**

Model	CR-100	CR-120	CR-150	CR-200	CR-300	CR-400	CR-500	CR-1000
Turning Capacity	100 tons	120 tons	150 tons	200 tons	300 tons	400 tons	500 tons	1000 tons
Loading Capacity-Drive	50 tons	60 tons	75 tons	100 tons	150 tons	200 tons	250 tons	500 tons
Loading Capacity-Idler	50 tons	60 tons	75 tons	100 tons	150 tons	200 tons	250 tons	500 tons
Vessel size	570-6800mm	570-6800mm	570-6800mm	570-6800mm	570-6800mm	570-6800mm	1000-7000mm	1500-8000mm
Adjust Way	Bolt adjustment							
Motor Power	2*3 KW	2*3 KW	2*4 KW	2*4 KW	2*5.5 KW	2*5.5 KW	2*7.5 KW	2*15 KW
Rotation Speed	100-1000mm/min Variable Frequency Driver							
Roller wheels	Rubber / PU / Steel Wheels all available				Steel Wheels			
Roller size	Φ500*400mm	Φ500*440mm	Φ500*600mm	Φ600*645mm	Φ700*300mm	Φ700*350mm	Φ800*400mm	Φ900*500mm
Voltage	220V / 380V / 415V / 440V / 480V / 575V ~ 50/60Hz 3Phase							
Control system	Remote hand box 8m cable (Rotation Forward & Reverse / Stop / Emergency Stop / Rotation speed display)							
Color	RAL 3003 RED+9005 Black							
Optional	Two Drive Units Can be Synchronous Rotation to get Double Load Turning Capacity.							

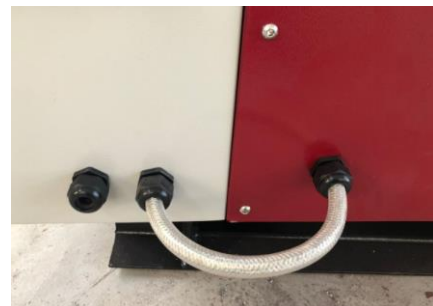

**FT SERIES/ FIT UP GROWING LINE**

**FT INTRODUCTION**

During two-pipe butt welding, sometimes we need to adjust the pipe position up or down to ensure the butt position is suitable for welding. Hydraulic FIT UP welding rollers will help adjust the pipe butt position via the cylinders. In the assembly line, they are always used together with CR or SAR series rollers equipped with traveling wheels



Growing Line



V Shape Delivery Roller



Hydraulic cylinders up / down



Manual Traveling Wheels

**20 TO 150 TON LOAD CAPACITY  
FT SPECIFICATIONS //// PARAMETERS TABLE**

Model	FT-20	FT-30	FT-40	FT-50	FT-60	FT-80	FT-100	FT-150
Turning Capacity	20 tons	30 tons	40 tons	50 tons	60 tons	80 tons	100 tons	150 tons
Loading Capacity-Drive	10 tons	15 tons	20 tons	25 tons	30 tons	40 tons	50 tons	75 tons
Loading Capacity-Idler	10 tons	15 tons	20 tons	25 tons	30 tons	40 tons	50 tons	75 tons
Vessel size	500-3500 mm	500-4000 mm	500-4500mm	500-4500mm	500-4500mm	500-4500mm	1000-5000mm	1000-5000mm
Adjust Way	Hydraulic Jack Up only / Idler Turning							
Roller wheels	Rubber / PU / Steel Wheels all available							
Roller size	Φ300*180mm	Φ350*220mm	Φ400*220mm	Φ400*220mm	Φ450*300mm	Φ500*360mm	Φ500*400mm	Φ500*400mm
Voltage	220V / 380V / 415V / 440V / 480V / 575V ~ 50/60Hz 3Phase							
Control system	Remote hand box 8m cable / Wireless Hand Box (Jack up / Jack down / Emergency Stop)							
Color	RAL 3003 RED+9005 Black							

**FT SERIES/ FIT UP GROWING LINE**



Hydraulic cylinder horizontal in / out



Hydraulic roller with traveling wheels



200Ton Hydraulic Up Down



600Ton Growing Line

**200 TO 1000 TON LOAD CAPACITY  
FT SPECIFICATIONS //// PARAMETERS TABLE**

Model	FT-200	FT-300	FT-400	FT-500	FT-1000
Turning Capacity	200 tons	300 tons	400 tons	500 tons	1000 tons
Loading Capacity-Drive	100 tons	150 tons	200 tons	250 tons	500 tons
Loading Capacity-Idler	100 tons	150 tons	200 tons	250 tons	500 tons
Vessel size	1000-5500 mm			1000-6000mm	
Adjust Way	Hydraulic Jack Up only / Idler Turning				
Roller wheels	Rubber / PU / Steel Wheels all available		Steel Wheels		
Roller size	Φ600*400mm	Φ700*400mm	Φ700*350mm	Φ800*400mm	Φ900*500mm
Voltage	220V / 380V / 415V / 440V / 480V / 575V ~ 50/60Hz 3Phase				
Control system	Remote hand box 8m cable / Wireless Hand Box (Jack up / Jack down / Emergency Stop )				
Color	RAL 3003 RED+9005 Black				





**GONAWELD**

<http://gonaweld.com>

## **SAR SERIES / SELF ALIGNING WELDING ROLLERS**

### **SAR INTRODUCTION**

Compared to CR series rollers, SAR series rollers feature a construction with wheels that can be automatically positioned to accommodate vessels of varying diameters around a constant center-line. They do not need to move the roller head in or out to match different diameter vessels. Additionally, each SAR series roller includes one drive unit and one idler unit. Rubber wheels, PU (Polyurethane) wheels, and Steel wheels are all available according to the project demands.

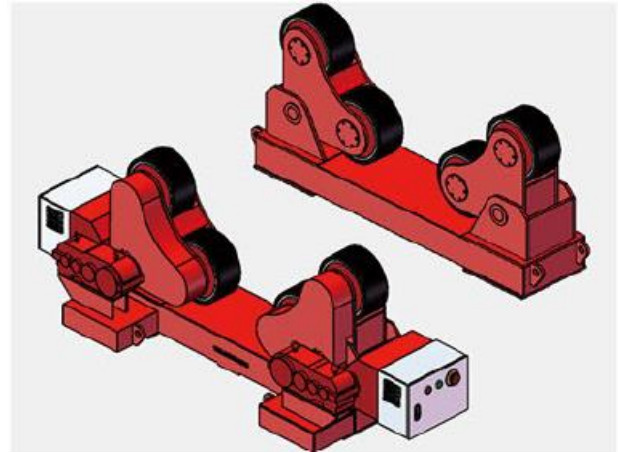

SAR-10



SAR-20 With Bolt Adjustment



SAR-60 With Motorized Wheels

**5 TO 80 TON LOAD CAPACITY**





**GONAWELD**

<http://gonaweld.com>

**SAR SPECIFICATIONS //// PARAMETERS TABLE**

Model	SAR-5	SAR-10	SAR-20	SAR-30	SAR-40	SAR-50	SAR-60	SAR-80
Turning Capacity	5 tons	10 tons	20 tons	30 tons	40 tons	50 tons	60 tons	80 tons
Loading Capacity-Drive	2.5 tons	5 tons	10 tons	15 tons	20 tons	25 tons	30 tons	40 tons
Loading Capacity-Idler	2.5 tons	5 tons	10 tons	15 tons	20 tons	25 tons	30 tons	40 tons
Vessel size	250-2300mm	320-2800mm	500-3500mm	900-4200mm	600-4200mm	800-4200mm	750-4800mm	850-5000mm
Adjust Way	Self Aligning Rollers							
Motor Power	0.75 KW	1.1 KW	1.5 KW	1.5 KW	2*1.5 KW	2*2.2 KW	2*2.2 KW	2*3 KW
Rotation Speed	100-1000mm/min Variable Frequency Driver							
Roller wheels	Rubber / PU / Steel Wheels							
Roller size	Φ250*140 mm	Φ300*10 mm	Φ350*180 mm	Φ350*200 mm	Φ400*200 mm	Φ400*200 mm	Φ450*200 mm	Φ500*220 mm
Voltage	220V / 380V / 415V / 440V / 480V / 575V ~ 50/60Hz 3Phase							
Control system	Remote hand box 8m cable (Rotation Forward / Stop / Rotation Reverse / Emergency Stop / Rotation speed display)							
Color	RAL 3003 RED+9005 Black							

**SAR INTRODUCTION**



SAR-100 With Motorized Traveling Wheels



100Ton For 5500mm Diameter Vessels



SAR-200 Traveling With PU Wheels



SAR-100 For 6000mm Diameter Vessels



SAR-100 At Working Site



2 Sets Drive Units With Synchronous Rotation



**GONAWELD**

<http://gonaweld.com>

**100 TO 500 TON LOAD CAPACITY  
SAR SPECIFICATIONS //// PARAMETERS TABLE**

Model	SAR-100	SAR-120	SAR-150	SAR-200	SAR-300	SAR-400	SAR-500
Turning Capacity	100 tons	120 tons	150 tons	200 tons	300 tons	400 tons	500 tons
Loading Capacity-Drive	50 tons	60 tons	75 tons	100 tons	150 tons	200 tons	250 tons
Loading Capacity-Idler	50 tons	60 tons	75 tons	100 tons	150 tons	200 tons	250 tons
Vessel size	250-2300mm	320-2800mm	500-3500mm	900-4200mm	600-4200mm	800-4200mm	750-4800mm
Adjust Way	Self Aligning Rollers						
Motor Power	2*3 KW	2*3 KW	2*4 KW	2*4 KW	2*5.5 KW	2*5.5 KW	2*7.5 KW
Rotation Speed	100-1000mm/min Variable Frequency Driver						
Roller wheels	Rubber / PU / Steel Wheels				Steel Wheels		
Roller size	Φ500*280 mm	Φ500*280 mm	Φ500*300 mm	Φ600*400 mm	Φ700*250 mm	Φ700*300 mm	Φ800*300 mm
Voltage	220V / 380V / 415V / 440V / 480V / 575V ~ 50/60Hz 3Phase						
Control system	Remote hand box 8m cable (Rotation Forward & Reverse / Stop / Emergency Stop / Rotation speed display)						
Color	RAL 3003 RED+9005 Black						



## C&B COLUMN BOOM MANIPULATOR

### MD Column Boom Manipulator

The Column Boom provides excellent welding results and maximum productivity through consistent and accurate placement of welding heads for automatic welding processes, including inside, outside, longitudinal, and circumferential welding applications.

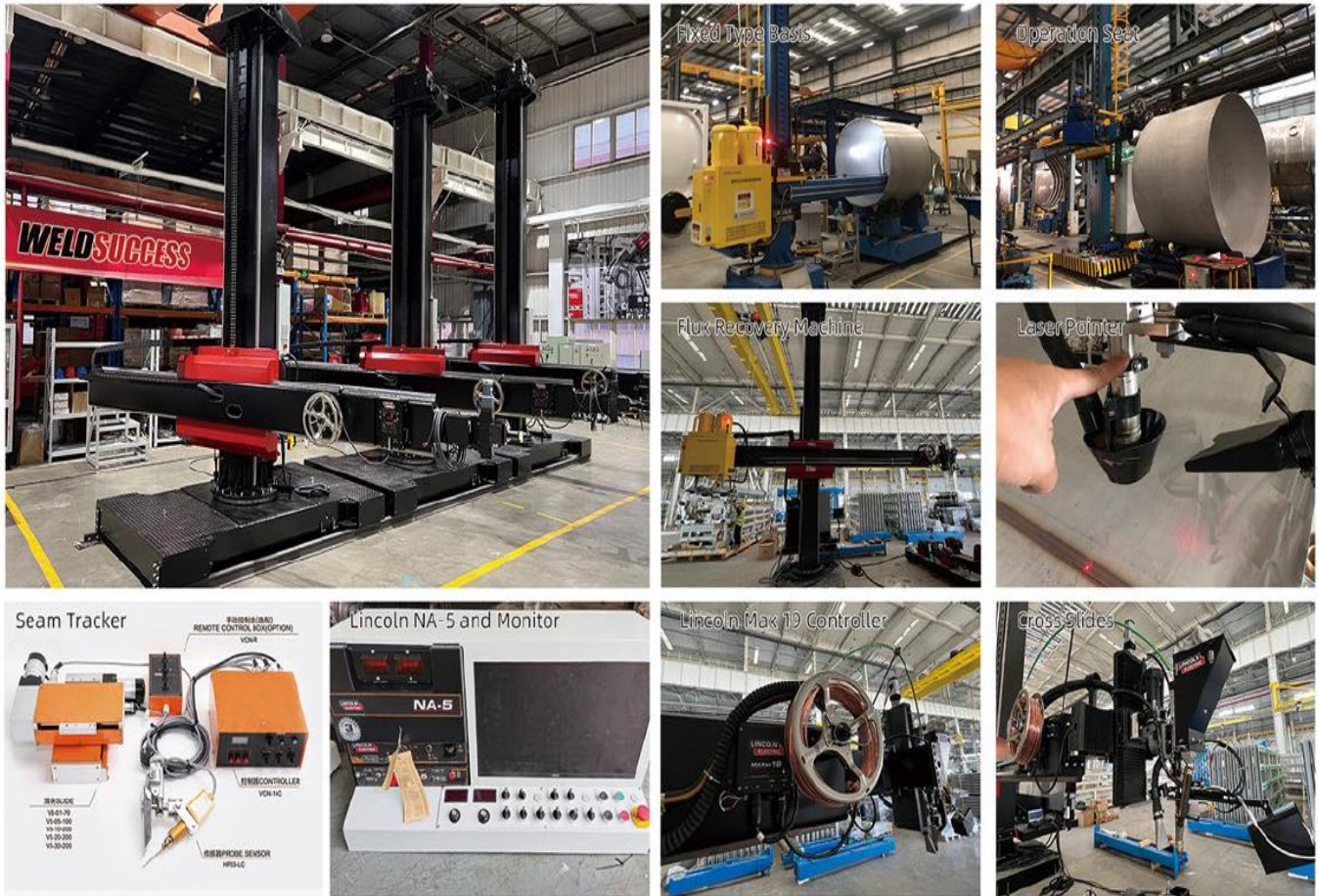

**LIGHT DUTY & MIDDLE DUTY C&B**

**LD/MD SPECIFICATIONS //// PARAMETERS TABLE**

Items	LD 1.5X1.5	LD 2X2	LD 3X3	MD 3X3	MD 4X4	MD 5X5	MD 6X6	MD 7X7	MD 8X8	MD 10X10
Boom vertical stroke (mm)	1000	2000	3000	3000	4000	5000	6000	7000	8000	10000
Vertical travel speed	1100 mm/min			1100 mm/min						
Boom Horizontal	1000	2000	3000	3000	4000	5000	6000	7000	8000	10000
Boom end load capacity	150 kg for TIG / Single SAW head only			250 kg / Single & Tandem SAW Head approval.						
Horizontal travel speed	175-1750 mm/min									
Traveling way	Fixed Type / Motorized Traveling									
Rotation way	±180° Manual rotation with lock (Standard) / Motorized Rotation Available (Special Request)									
Boom end cross-slides	Motorized cross slides 150*150 mm									
Control system	Remote hand box 15m cable									
Voltage	220V / 380V / 415V / 440V / 480V / 575V ~ 50/60Hz 3Phase									
Color	RAL 3003 RED+9005 Black									
Optional	1. Flux recovery machine.									
	2. Laser pointer & welding camera & Monitor									
	3. Integrated to SAW power source and linkage with welding rotator for longitudinal & circular seam welding by PLC control.									
	4. All the C&B size can be mixed like MD 3X4 / 5X3 / 4X8 etc.									

## HBJ SERIES / STANDARD 2 AXIS WELDING POSITIONER

### HBJ INTRODUCTION

The HBJ Series positioner provides 360° rotation of a workpiece along with a 0-90° forward tilt to better position weldments for both manual and automatic welding. All-fabricated steel frames and bases support rotation with heavy bearings driven by worm-gear reducers, ensuring enhanced safety and durability. The rotation motor is an inverter-controlled variable-frequency AC-type, providing a full range of variable-speed control with excellent speed regulation. The tilting motor is a brake motor, ensuring the table can stop at any angle. Control boxes utilize variable-frequency AC control electrical systems with full CE certification to ensure all our products meet safe working loads in the weld automation industry.



**600 KG TO 50 TON LOAD CAPACITY  
HBJ SPECIFICATIONS //// PARAMETERS TABLE**

Model	HBJ-06	HBJ-10	HBJ-20	HBJ-30	HBJ-50	HBJ-100	HBJ-200	HBJ-300	HBJ-500
Load Capacity	600kg	1000kg	2000kg	3000kg	5000kg	10000kg	20000kg	30000kg	50000kg
Table diameter	1000mm	1000mm	1200mm	1400mm	1500mm	2000mm	2000mm	2200mm	3000mm
Rotation motor	0.55 kw	0.75 kw	1.1 kw	1.1 kw	1.5 kw	3 kw	4 kw	5.5 kw	11 kw
Rotation speed	0.12-1.2 rpm Variable			0.05-0.5 rpm Variable					
Tilting angle	0-90 °/ 0-135°								
Tilting motor	0.75 kw	0.76 kw	0.77 kw	0.78 kw	0.79 kw	0.80 kw	0.81 kw	0.82 kw	0.83 kw
Tilting speed	1.1 rpm	0.23 rpm							
Voltage	220V / 380V / 415V / 440V / 480V / 575V ~ 50/60Hz 3Phase								
Control system	Remote control with 8m cable (Rotation Forward & Reverse / Tilting up & down / Emergency Stop / Rotation speed display)								
Color	RAL 3003 RED+9005 Black								
Chucks	3 Jaw chucks available / Diameter 200~2000mm capacity chuck								
Optional	Servo & PLC control integrated								



**GONAWELD**

<http://gonaweld.com>

## **HBS SERIES / MANUAL HEIGHT ADJUST 3 AXIS WELDING POSITIONER**

### **HBS INTRODUCTION**

Compared to the HBJ series positioner, the HBS series positioner adds an axis to adjust the center height via manual bolt height adjustment. This feature allows it to accommodate different height jobs.





**GONAWELD**

<http://gonaweld.com>

**600 KG TO 50 TON LOAD CAPACITY  
HBJ SPECIFICATIONS //// PARAMETERS TABLE**

Model	HBS-06	HBS-10	HBS-20	HBS-30	HBS-50	HBS-100	HBS-200	HBS-300	HBS-500
Load Capacity	600kg	1000kg	2000kg	3000kg	5000kg	10000kg	20000kg	30000kg	50000kg
Table diameter	1000mm	1000mm	1200mm	1400mm	1500mm	2000mm	2000mm	2200mm	3000mm
Rotation motor	0.55 kw	0.75 kw	1.1 kw	1.1 kw	1.5 kw	3 kw	4 kw	5.5 kw	11 kw
Rotation speed	0.12-1.2 rpm Variable				0.05-0.5 rpm Variable				
Tilting angle	0-90 °/ 0-135°								
Tilting motor	0.75 kw	0.76 kw	0.77 kw	0.78 kw	0.79 kw	0.80 kw	0.81 kw	0.82 kw	0.83 kw
Tilting speed	1.1 rpm	0.23 rpm							
Height adjust	Manual height adjust with Bolt								
Voltage	220V / 380V / 415V / 440V / 480V / 575V ~ 50/60Hz 3Phase								
Control system	Remote control with 8m cable (Rotation Forward & Reverse / Tilting up & down / Emergency Stop / Rotation speed display)								
Color	RAL 3003 RED+9005 Black								
Chucks	3 Jaw chucks available / Diameter 200 ~2000mm capacity chuck								
Optional	Servo & PLC control Integrated								





**GONAWELD**

<http://gonaweld.com>

## **YHB SERIES / HYDRAULIC 3 AXIS WELDING POSITIONER**

### **YHB Hydraulic 3 Axis Positioner**

The YHB Hydraulic 3-axis Series positioner provides 360° rotation and height adjustment of a workpiece, along with a 0-90° forward tilt to better position weldments for both down-hand and automatic welding. Height adjustment and tilting angle are achieved via hydraulic cylinders. The rotation motor is an inverter-controlled variable-frequency AC-type, providing a full range of variable-speed control with excellent speed regulation. Control boxes utilize variable-frequency AC control electrical systems with full CE certification to ensure all our products meet safe working loads in the weld automation industry.



Hydraulic Pump



Electric Conduction Device



Hydraulic Meter

**1 TO 20 TON LOAD CAPACITY  
YHB SPECIFICATIONS //// PARAMETERS TABLE**

**1TON TO 20TON LOAD CAPACITY**

<b>YHB SPECIFICATIONS</b> ///		<b>PARAMETERS TABLE</b>				
Model	YHB-10	YHB-20	YHB-30	YHB-50	YHB-100	YHB-200
Turning Capacity	1 Ton maximum	2 Ton maximum	3 Ton maximum	5 Ton maximum	10 Ton maximum	20 Ton maximum
Table diameter	1200mm	1200mm	1400mm	1500mm	2000mm	2200mm
Rotation motor	0.75 KW	1.1 KW	1.1 KW	1.5 KW	3 KW	4 KW
Rotation speed	0.05-0.5 rpm Variable					
Tilting angle	0-130 degree on the bottom & 0-90 degree on the top					
Elevator way	Hydraulic Cylinders Up / Down					
Center height	700 ~ 1650 mm	700 ~ 1650 mm	700 ~ 1800 mm	790 ~ 1700 mm	1130 ~ 2468 mm	1130 ~ 2468 mm
Voltage	220V / 380V / 415V / 440V / 480V / 575V ~ 50/60Hz 3Phase					
Control system	Remote control 8m cable (Rotation Forward & Reverse / Tilting up & down / Emergency Stop / Rotation speed display)					
Color	RAL 3003 RED+9005 Black					
Options	3 jaw chucks					

## HB HORIZONTAL TURNING TABLE

### HB INTRODUCTION

The HB Series Horizontal Turning Table provides 360° rotation of a workpiece to better position weldments for both manual and automatic welding. All-fabricated steel frames and bases support rotation with heavy bearings driven by worm-gear reducers, ensuring enhanced safety and durability. The rotation motor is an inverter-controlled variable-frequency AC-type, providing a full range of variable-speed control with excellent speed regulation. Control boxes utilize variable-frequency AC control electrical systems with full CE certification to ensure all our products meet safe working loads in the weld automation industry. Additionally, it can integrate with servo motors and PLC control to work with robots or preset the rotation angle.

Items	HB-10	HB-20	HB-30	HB-50	HB-100	HB-200	HB-300	HB-500
Load Capacity	1 tons	2 tons	3 tons	5 tons	10 tons	15 tons	20 tons	50 tons
Table diamete	φ1200 mm	φ1300 mm	φ1400 mm	φ1500 mm	φ2000 mm	φ2200 mm	Designed up to φ7000 mm	
Rotation speed	0.12~1.2 rpm	0.12~1.2 rpm	0.05~0.5 rpm	0.05~0.5 rpm	0.05~0.5 rpm	0.05~0.5 rpm	0.05~0.5 rpm	0.05~0.5 rpm
Control system	Remote hand box 8m cable (Rotation Forward & Reverse / Rotation Pause / Emergency Stop / Rotation speed display)							
Voltage	220V / 380V / 415V / 440V / 480V / 575V ~ 50/60Hz 3Phase							
Color	RAL 3003 RED+9005 Black							
<p><b>Special Customized:</b> (Not supplied to common machine)</p> <p>* To integrated with servo motor and PLC control to work with robot or preset the rotation angle.</p>								

## Control System Spare Parts



DANFOSS



SCHNEIDER



EMERSON



ELECTRIC CABINET



3 AXIS HYDRAULIC POSITIONER HAND BOX



WIRELESS HAND BOX



WELDING ROLLERS HAND BOX



HDXBSCN CONTROL PLUGS



WELDING ROLLERS REMOTE HAND BOX



COLUMN BOOM HAND BOX



SCHNEIDER HAND BOX



FOOT PEDAL

## CNC FLAME/PLASMA CUTTING MACHINE

### CNC INTRODUCTION //// PARAMETERS TABLE

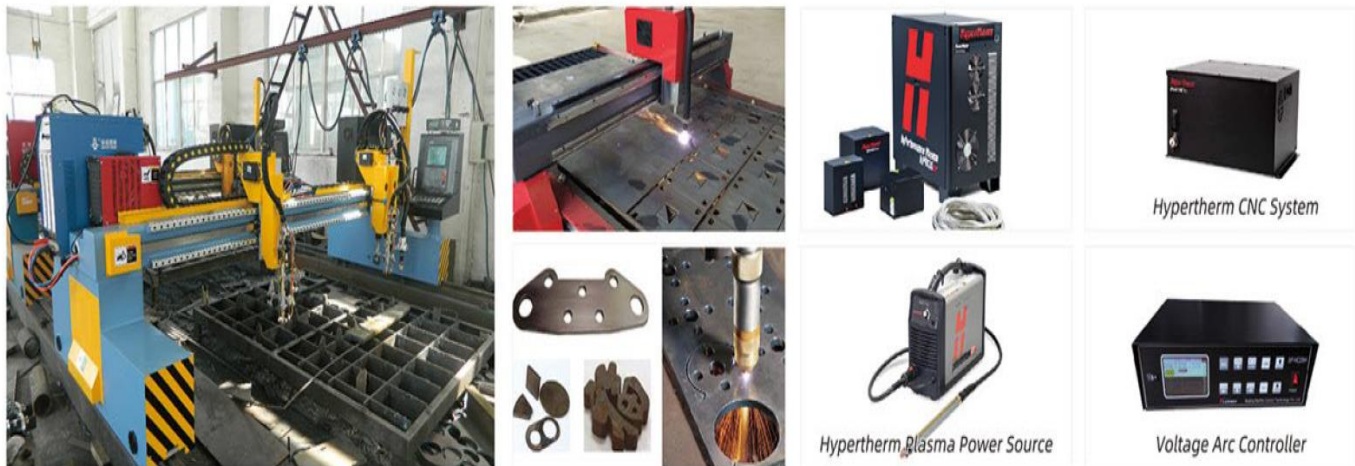

Rail span(mm)	3000	4000	5000	6000	7000	8000
Cutting width ( mm )	2300	3200	4200	5200	6200	7100
Drive way	Single drive			Double drive		
Rail length	Standard rail length is 15m,which can be extended or shortened on customer requirements.					
Torch quantity	Standard configuration is 2 CNC torches and 9 strip torches.which can be altered on customer reuirements.					
Cutting thickness	Flame:6-10mm,which can be increased on customer requirements up to 350mm Plasma:we recommend plasma power source model on customer requirement.					
Travel speed	Max: 12000mm/min					
Cutting speed	Max.6000mm/min(Set upon cutting material)					
Precision	Conform to JB/5102-1999					
Cuttong quanlity and size warp	Flame:Conform to JB/T10045.3-1999Plasma:Conform to JB/T10045.4-1999					



**GONAWELD**

<http://gonaweld.com>

Model	Flame	Plasma
pipe diameter	Φ50-600mm	
pipe thickness	5-50mm	2-20mm
pipe length	6000-12000mm	
control axis	2 Axis 3 Axis 4 Axis 5 Axis	



Beveling Workpiece





**GONAWELD**

<http://gonaweld.com>

**APPLICATION**



Hydraulic Height Adjust Head Stock



HYDRAULIC HEIGHT ADJUST STANDARD



L Shape



Spool Rotator for Elbow Welding



STWB Head Tail Stock Positioner



HEAD STOCK WITH SUPPORT ROLLER



Vessels Head Positioner



Two Columns Positioner



Lead Screw Rollers



500TON STEEL WHEELS ROLLERS



300Ton Steel Wheels Rollers



200Ton CHENTA Reducer Rollers



Drives Synchronous Rotation



200TON ONSHORE LINE



200Ton FIT UP Rollers



Offshore Line



SAR with Bolt Adjust Rollers



LARGE WIDTH PU WHEELS FOR THIN THICKNESS VESSELS



SAR With Motorized Traveling Wheels

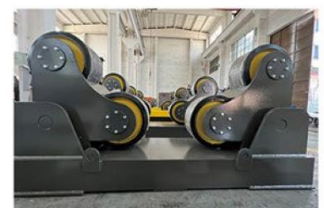

500Ton Self Aligning Rollers

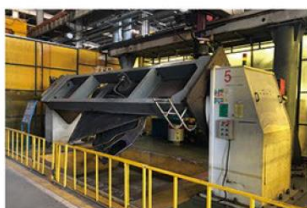

Head Tail Stock Positioner



BEAM OVERTURNING POSITIONER

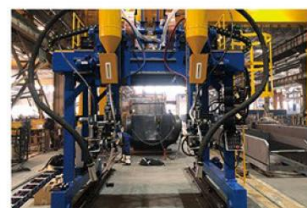

Beam Gantry Welding Machine



7000mm Diameter Turning Table

**PACKAGE & DELIVERY**

